

SELF-OSCILLATING MONITOR Mod. FI-MM3 BZ-A



DESCRIPTION

The FI-MM3 BZ-A UL listed monitor is a self-oscillating monitor designed for fixed installation and for mobile mounted units. FI-MM3 BZ-A is a cast monitor and, thanks to the high quality materials used in its composition, it is commonly installed in petrochemical, heavy industrial, marine and high corrosive environments.

The monitor has cast nickel aluminum bronze 3 inch water way, with a maximum UL listed flowrate of 1000 GPM and it is mounted on a self-oscillating st. steel joint provided of an anodized aluminum self-oscillating hydraulic mechanism.

The hydraulic turbine operates with a minimal flow diverted from the monitor inlet, requiring no external hydraulic or electrical power source. The monitor can oscillate within a range of 0° to 340°, adjustable each 20°, with the oscillation angle configurable anywhere within the full 360° field of operation. The self-oscillating function can be deactivated by closing the integrated ball valve. In manual mode, vertical and horizontal movements are controlled via a handle, while the standby position can be secured using the locking knobs.

FI-MM3 BZ-A is UL Listed with FI-BA BZ Nozzle (without pickup tube) and FI-ABA BZ Nozzle (with pickup tube).

The monitor/nozzle combination is UL Listed as part of a fire extinguishing system with specific foam concentrates. Listed system components can be found at <https://iq.ulprospector.com>.

UL Listed GFXX.EX29259 – Foam Monitors. The monitor is fluorine free compatible.

Technical characteristics	
Model	FI-MM3 BZ-A
Body material	Nickel aluminum bronze
Self-oscillating mechanism	In anodized aluminum mounted on a st. steel joint
Water turbine consumption	40 lt/min at 3 bar
Approvals	UL listed, fluorine free compatible
UL listed flowrates	250, 350, 500, 750 or 1,000 GPM (Please refer to UL Product IQ for actual Listing details)
Min. & Max. working pressure	44 - 175 PSI
Inlet connection	Flanged ANSI or UNI PN 16
Outlet connection	3" threaded bsp m
Weight	57 kg
Travel	Rotation: 340° in self-oscillating mode adjustable each 20° Elevation: + 85° - 52°
Paint cycle	Epoxi primer and polyurethanic enamel color red RAL 3000. Natural finish for nozzle.

DIMENSIONS

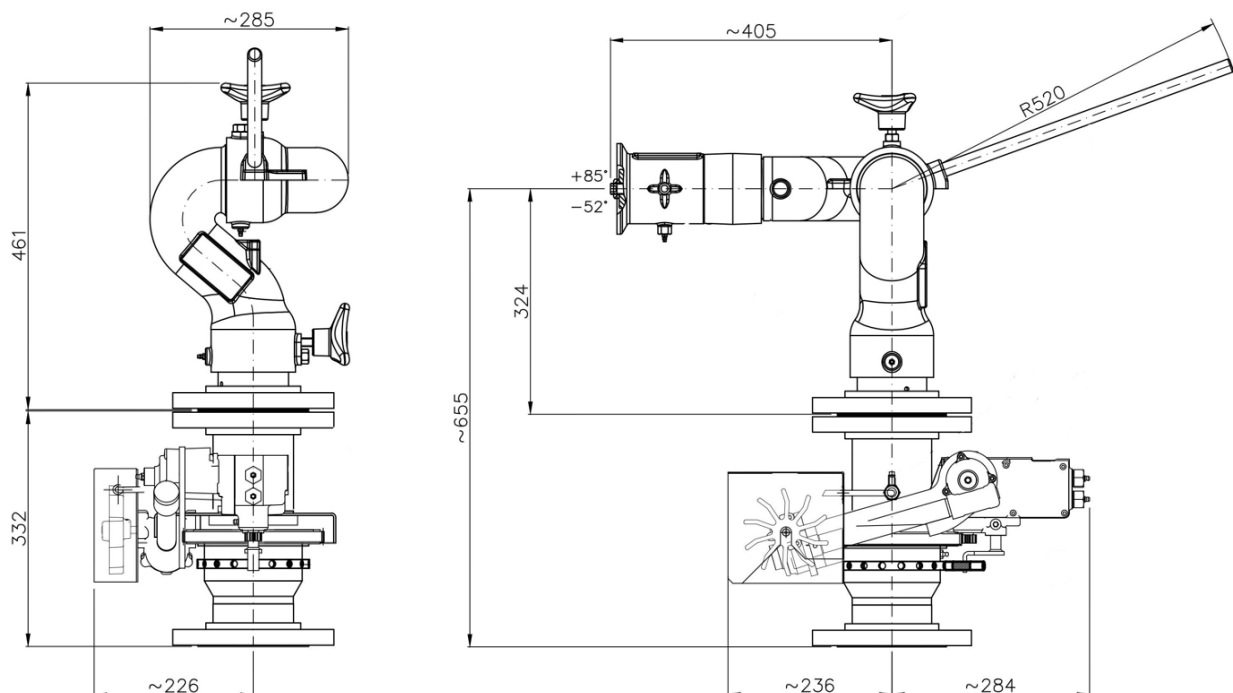

NOZZLE SELECTION

FI-BA BZ: Non-self-inducting nozzle is for use with water or with foam solution supplied via a suitable bladder tank or other foam mixing systems.

FI-ABA BZ: Self-inducting nozzle equipped with pick-up tube in order to use the flow of water through the internal waterway to aspirate the foam from a foam container and mix it into a foam solution. Mixing is carried out at 3%. The foam induction can be stopped using the supplied ball valve in order to discharge water only.

FI-BA BZ DIMENSIONS

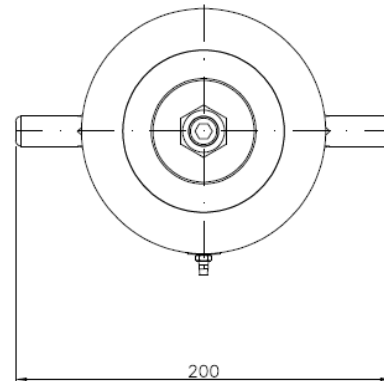
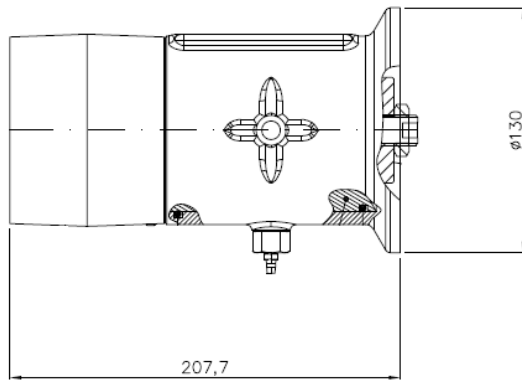

Performance data & technical characteristics

Model	Material	Weight KG	Flowrate GPM	Monitor inlet pressure PSI
FI-BA BZ 250	Nickel aluminum bronze	7	250	100
FI-BA BZ 350	Nickel aluminum bronze	7	350	100
FI-BA BZ 500	Nickel aluminum bronze	7	500	100
FI-BA BZ 750	Nickel aluminum bronze	7	750	100
FI-BA BZ 1000	Nickel aluminum bronze	7	845-1000	100-145

FI-ABA BZ DIMENSIONS

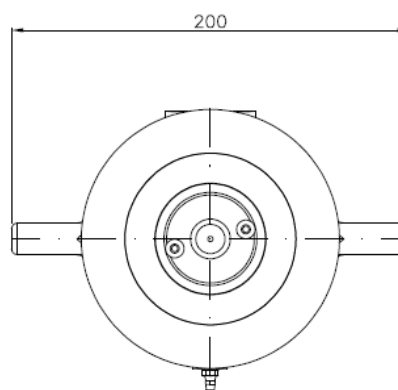
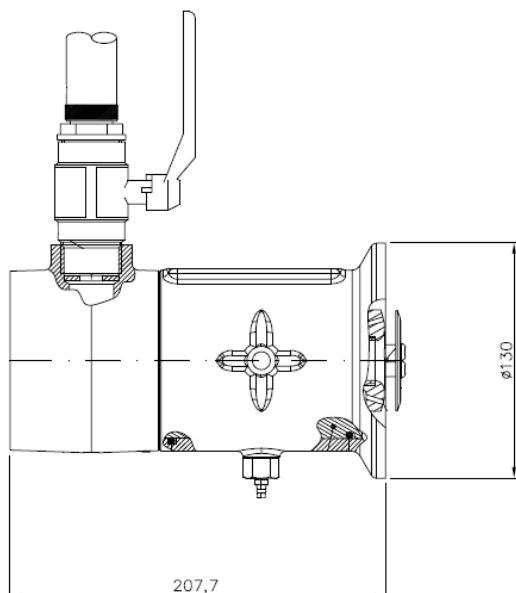

Performance data & technical characteristics

Model	Material	Weight KG	Flowrate GPM	Monitor inlet pressure PSI	Induction
FI-ABA BZ 250	Nickel aluminum bronze	8	250	100	3%
FI-ABA BZ 350	Nickel aluminum bronze	8	350	100	3%
FI-ABA BZ 500	Nickel aluminum bronze	8	500	100	3%
FI-ABA BZ 750	Nickel aluminum bronze	8	750	100	3%
FI-ABA BZ 1000	Nickel aluminum bronze	8	845-1000	100-145	3%